

LOADING

Clause 8.1 of British Standard Code of Practice CP3: Chapter V: Part 1 specifies:

1. A light duty loading of 220 N/m (Light access stairs, gangways and the like not more than 600mm wide).
2. A medium duty loading of 360 N/m (Light access stairs, gangways and the like more than 600mm wide: stairways, landings balconies, private and domestic).
3. A heavy duty loading of 740 N/m (All other stairways, landings and balconies and all parapets and handrails to roofs). This greater loading should also be observed when there is any possibility of the handrail being leant on by a crowd of people using the stair or gangway as an observation platform.

Ramsay Access Head Office

61 West High Street

Forfar, Angus

Scotland DD8 1BH

Tel: +44 (0)1307 462255

Fax: +44 (0)1307 466956

Email: ian@ramsayladders.co.uk

www.ramsayaccess.com

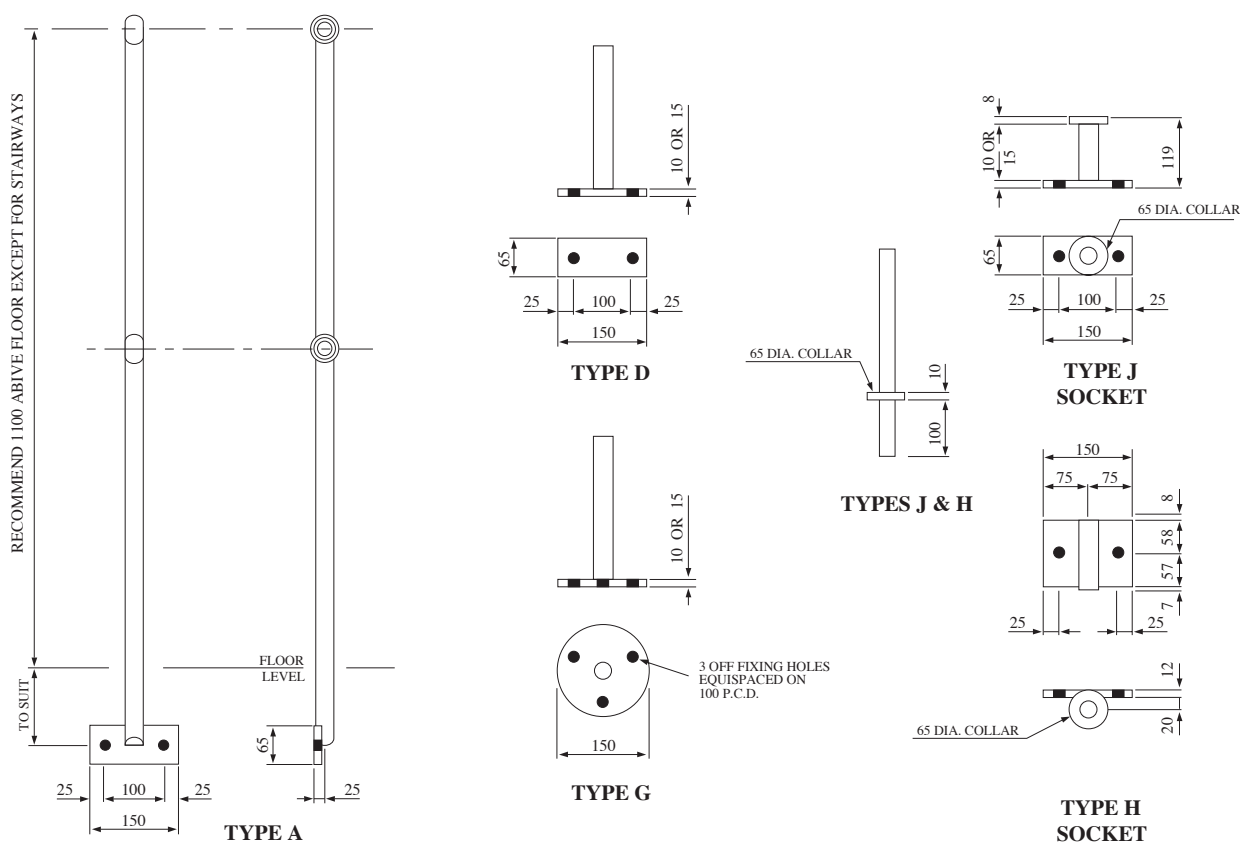

SOLID AND TUBULAR HANDRAIL STANDARDS - Max pitch based on 1100mm high standard

LOADING CLASS	NOMINAL BALL DIA.	SHANK SIZE	MAXIMUM PITCH	SOLID OR TUBULAR	RAIL SIZE	GRUB SCREW SIZE
1	70	25 N.B. (M)	1480	T	25 N.B. (M)	A
1	70	32 N.B. (M)	1800	T	25 N.B. (M)	A
1	60	32 O.D.	1800	S	25 N.B. (M)	C
1	60	38 O.D.	1800	S	25 N.B. (M)	C
1	70	38 O.D.	1800	S	32 N.B. (M)	C
2	70	25 N.B. (M)	900	T	25 N.B. (M)	A
2	60	32 O.D.	1222	S	25 N.B. (M)	C
2	70	32 N.B. (M)	1550	T	25 N.B. (M)	A
2	70	32 N.B. (H)	1750	T	25 N.B. (M)	A
2	60	38 O.D.	1800	S	25 N.B. (M)	C
2	70	38 O.D.	1800	S	32 N.B. (M)	C
3	80	32 N.B. (M)	750	T	32 N.B. (M)	B
3	80	32 N.B. (H)	850	T	32 N.B. (M)	B
3	80	40 N.B. (M)	970	T	32 N.B. (M)	B
3	60	38 O.D.	1092	S	25 N.B. (M)	C
3	70	38 O.D.	1092	S	32 N.B. (M)	C
3	80	40 N.B. (H)	1150	T	32 N.B. (M)	B

- M Denotes medium quality tube.
- H Denotes heavy quality tube.
- A Denotes M6x16 zinc plated cone pointed socket set screws.
- B Denotes M6x20 zinc plated cone pointed socket set screws.
- C Denotes M10x16 zinc plated cone pointed socket set screws.